



Conveyor Oven
Model CE-CN-0356
Item 48387
Instruction Manual



STOP
DO NOT RETURN
THIS PRODUCT TO THE STORE

For questions or assistance with this product call OMCAN Toll Free: 1 800 465 0234 Customer Service or visit the Support section of www.omcan.com

Revised - 12/01/2022



Toll Free: 1-800-465-0234
Fax: 905-607-0234
Email: service@omcan.com
www.omcan.com



NEMA
6 - 20
250 VAC / 20 AMP
RECEPTACLE

Table of Contents

Model CE-CN-0356

Section	Page
General Information -----	3 - 4
Safety and Warranty -----	4 - 7
Technical Specifications -----	8
Installation -----	8 - 9
Operation -----	9
Maintenance -----	9 - 11
Parts Breakdown -----	12 - 13
Electrical Schematics -----	14
Warranty Registration -----	15



General Information

Omcan Manufacturing and Distributing Company Inc., Food Machinery of America, Inc. dba Omcan and Omcan Inc. are not responsible for any harm or injury caused due to any person's improper or negligent use of this equipment. The product shall only be operated by someone over the age of 18, of sound mind, and not under the influence of any drugs or alcohol, who has been trained in the correct operation of this machine, and is wearing authorized, proper safety clothing. Any modification to the machine voids any warranty, and may cause harm to individuals using the machine or in the vicinity of the machine while in operation.

CHECK PACKAGE UPON ARRIVAL

Upon receipt of an Omcan shipment please inspect for external damage. If no damage is evident on the external packaging, open carton to ensure all ordered items are within the box, and there is no concealed damage to the machine. If the package has suffered rough handling, bumps or damage (visible or concealed), please note it on the bill of lading before accepting the delivery and contact Omcan within 24 hours, so we may initiate a claim with the carrier. A detailed report on the extent of the damage caused to the machine must be filled out within three days, from the delivery date shown in the shipping documents. Omcan has no recourse for damaged products that were shipped collect or third party.

Before operating any equipment, always read and familiarize yourself with all operation and safety instructions.

Omcan would like to thank you for purchasing this machine. It's of the utmost importance to save these instructions for future reference. Also save the original box and packaging for shipping the equipment if servicing or returning of the machine is required.

Omcan Fabrication et distribution Compañie Limité et Food Machinery d'Amérique, dba Omcan et Omcan Inc. ne sont pas responsables de tout dommage ou blessure causé du fait que toute personne ait utilisé cet équipement de façon irrégulière. Le produit ne doit être exploité que par quelqu'un de plus de 18 ans, saine d'esprit, et pas sous l'influence d'une drogue ou d'alcool, qui a été formé pour utiliser cette machine correctement, et est vêtu de vêtements de sécurité approprié. Toute modification de la machine annule toute garantie, et peut causer un préjudice à des personnes utilisant la machine ou des personnes à proximité de la machine pendant son fonctionnement.

VÉRIFIEZ LE COLIS DÈS RÉCEPTION

Dès réception d'une expédition d'Omcan veuillez inspecter pour dommages externes. Si aucun dommage n'est visible sur l'emballage externe, ouvrez le carton afin de s'assurer que tous les éléments commandés sont dans la boîte, et il n'y a aucun dommage dissimulé à la machine. Si le colis n'a subi aucune mauvaises manipulations, de bosses ou de dommages (visible ou cachée), notez-le sur le bond de livraison avant d'accepter la livraison et contactez Omcan dans les 24 heures qui suivent, pour que nous puissions engager une réclamation auprès du transporteur. Un rapport détaillé sur l'étendue des dommages causés à la machine doit être rempli dans un délai de trois jours, à compter de la date de livraison indiquée dans les documents d'expédition. Omcan n'a aucun droit de recours pour les produits endommagés qui ont été expédiés ou cueilli par un tiers transporteur.

General Information

Avant d'utiliser n'importe quel équipement, toujours lire et vous familiariser avec toutes les opérations et les consignes de sécurité.

Omcán voudrais vous remercier d'avoir choisi cette machine. Il est primordial de conserver ces instructions pour une référence ultérieure. Également conservez la boîte originale et l'emballage pour l'expédition de l'équipement si l'entretien ou le retour de la machine est nécessaire.

Omcán Empresa De Fabricación Y Distribución Inc. Y Maquinaria De Alimentos De América, Inc. dba Omcán y Omcán Inc. no son responsables de ningún daño o perjuicio causado por cualquier persona inadecuada o el uso descuidado de este equipo. El producto solo podrá ser operado por una persona mayor de 18 años, en su sano juicio y no bajo alguna influencia de droga o alcohol, y que este ha sido entrenado en el correcto funcionamiento de esta máquina, y ésta usando ropa apropiada y autorizada. Cualquier modificación a la máquina anula la garantía y puede causar daños a las personas usando la máquina mientras esta en el funcionamiento.

REVISE EL PAQUETE A SU LLEGADA

Tras la recepción de un envío Omcán favor inspeccionar daños externos. Si no hay daños evidentes en el empaque exterior, abra el cartón para asegurarse que todos los artículos solicitados estén dentro de la caja y no encuentre daños ocultos en la máquina. Si el paquete ha sufrido un manejo de poco cuidado, golpes o daños (visible o oculto) por favor anote en la factura antes de aceptar la entrega y contacte Omcán dentro de las 24 horas, de modo que podamos iniciar una reclamación con la compañía. Un informe detallado sobre los daños causados a la máquina debe ser llenado en el plazo de tres días, desde la fecha de entrega que se muestra en los documentos de envío. Omcán no tiene ningún recurso por productos dañados que se enviaron a recoger por terceros.

Antes de utilizar cualquier equipo, siempre lea y familiarizarse con todas las instrucciones de funcionamiento y seguridad.

Omcán le gustaría darle las gracias por la compra de esta máquina. Es de la mayor importancia para salvar estas instrucciones para futuras consultas. Además, guarda la caja original y el embalaje para el envío del equipo si servicio técnico o devolución de la máquina que se requiere.

Safety and Warranty

IMPORTANT SAFEGUARDS

When using electrical appliances, basic safety precautions should always be taken, including the following:

1. Read all instructions.
2. To protect against risk of electrical shock, do not put appliance in water or other liquids.
3. Do not touch surfaces that may be hot.
4. Unplug from outlet when not in use, before putting on or taking off parts and before cleaning.



Safety and Warranty

5. Avoid coming in contact with moving parts.
6. Do not operate the appliance with a damaged cord or plug, or after the unit malfunctions, or is dropped or damaged in any manner.
7. Do not use outdoors.
8. Do not place near a hot gas or electric burner or heated oven.
9. Do not let cord hang over edge of table or counter, or touch hot surfaces.
10. This appliance is intent for commercial use only. This appliance is designed to be used in commercial areas.
11. This appliance is not intended for use by persons (including children) with reduced physical, sensory or mental capabilities, or lack of experience and knowledge, unless they have been given supervision or instruction concerning use of the appliance by a person responsible for their safety. Children should be supervised to ensure that they do not play with the appliance.
12. Do not use appliance for other than its intended use.
13. Where this appliance is to be positioned in close proximity to a wall, partitions, kitchen furniture, decorative finishes, etc., it is recommended that they be made of non-combustible material; if not, they shall be clad with a suitable non-combustible heat-insulating, material, and that the closest attention be paid to fire prevention regulations.
14. Close supervision is necessary when any appliance is used by or near children.
15. The use of accessory attachments not recommended by the appliance manufacturer may cause injuries.
16. Do not operate under wall cabinets.
17. To disconnect press the illuminated ON/OFF switch to OFF, then remove plug from wall outlet.
18. To avoid a risk of fire or electric shock, oversized bread, metal foil packages, or metal or plastic utensils must not be placed on the conveyor belt.
19. CAUTION –To reduce the risk of fire, the appliance is to be installed in non-combustible surroundings only, with no combustible material within 18 inches of the sides, front, or rear of the appliance or within 40 inches above the appliance. The appliance is to be mounted on floors of noncombustible construction with noncombustible flooring and surface finish and with no combustible material against the underside, or on noncombustible slabs or arches have no combustible material against the underside. Such construction shall in all cases extend not less.
20. WARNING: To avoid Conveyor Toaster malfunction, always keep the fan vents clean and clear.
21. WARNING: ELECTRICAL SHOCK HAZARD. Never attempt to dislodge food inside the Conveyor Toaster while the Conveyor Toaster is plugged in. Doing so could cause an electrical shock hazard or a risk of fire.
22. CAUTION: Parts of this Conveyor Toaster become hot during operation. Always use oven mitts when handling hot materials and allow metal parts to cool before cleaning.
23. Do not place anything on top of the Conveyor Toaster while it is operating or while it is hot.
24. Always keep hands, hair and cloth away from the wire bread feeder or conveyor belt.
25. Do not use water jet to clean this appliance.
26. Do not leave this appliance unattended during use.
27. Plug unit into a properly grounded electrical outlet of the correct voltage, size and plug configuration. If the plug and receptacle do not match, contact a qualified electrician to determine the proper voltage and size and install the proper electrical outlet.
28. The use of accessory attachments not recommended by the appliance manufacturer may cause injuries.
29. To avoid injury, turn the power switch off, allow to cool completely, and unplug unit from power source before performing any maintenance or cleaning.
30. To avoid electrical shock, always unplug the unit before performing cleaning or maintenance.

Safety and Warranty

31. To avoid electrical shock or personal injury, do not steam clean or use excessive water on the unit.
32. Locate the unit at the proper counter height, in an area that is convenient for use. The location should be level to prevent the unit or its contents from accidentally falling, and strong enough to support the weight of the unit and food.
33. Do not leave this appliance on overnight or for prolonged periods of non-use.
34. Always turn off the power switch before plugging cord into the wall socket. To disconnect, always turn off the power switch before unplugging from the wall socket.
35. It is recommended that this appliance not be moved when it remains hot.

SAVE THESE INSTRUCTIONS FOR COMMERCIAL USE ONLY

CAUTION!

- DO NOT toast bread, bread products, or pastries with fillings or toppings such as butter, cheese or ham, etc. in this Conveyor Toaster.
- DO NOT toast torn slices of bread.
- DO NOT place wrapped food into the wire feeder.

NOTES ON THE PLUG

This appliance has a grounded 3-prong plug. Connect to a properly grounded outlet only. If the plug does not fit fully into the outlet, contact a qualified electrician. Do not attempt to modify the plug in any way.

NOTES ON THE CORD

A short power supply cord has been provided to reduce the hazards resulting from becoming entangled in or tripping over a longer cord. An extension cord may be used with this appliance if care is properly exercised in its use. If an extension cord is used, the marked electrical rating of the extension cord must be at least as great as the electrical rating on this appliance. The longer cord should be arranged so that it will not drape over the counter top or table top where it can be pulled on by children or another person or tripped over accidentally.

ELECTRIC POWER

If the electrical circuit is overloaded with other appliances, your appliance may not operate properly. It should be operated on a separate electrical circuit from other appliances.

SAFETY

When finish the cooking, please switch off the power, It is advised the motor can not work continuously for over 4 hours.

Please take notice that the unit will still be too hot to handle immediately after use.

If the supply cord is damaged, it must be replaced by a special cord or assembly available from the manufacturer or its service agent.

These appliances are intended to be used for commercial applications, for example in kitchens of restaurants, canteens, hospitals and in commercial enterprises such as bakeries, butcheries, etc., but not for continuous mass production of food.



Safety and Warranty

RESIDENTIAL USERS: Vendor assumes no liability for parts or labor coverage for component failure or other damages resulting from installation in non-commercial or residential applications. The right is reserved to deny shipment for residential usage; if this occurs, you will be notified as soon as possible.

1 YEAR PARTS AND LABOUR BENCH WARRANTY

Within the warranty period, contact Omcan Inc. at 1-800-465-0234 to schedule a drop off to either an Omcan authorized service depot in the area, or to an Omcan Service warehouse to repair the equipment.

Unauthorized maintenance will void the warranty. Warranty covers electrical and part failures, not improper use.

Please see <https://omcan.com/disclaimer> for complete info.

WARNING:

The packaging components are classified as normal solid urban waste and can therefore be disposed of without difficulty.

In any case, for suitable recycling, we suggest disposing of the products separately (differentiated waste) according to the current norms.

DO NOT DISCARD ANY PACKAGING MATERIALS IN THE ENVIRONMENT!

Technical Specifications

Model	CE-CN-0356
Current	20A
Power	3600 W
Tunnel Opening	1.9 - 2.9" x 15" / 50 - 75 x 385mm
Conveyor Belt Dimensions	15" x 38" / 380 x 965mm
Tray Dimensions	15" x 10" / 382 x 256mm
Output Capacity per Hour	19 - 12" pizzas
	25 - 9" pizzas
Electrical	240V / 60Hz
Temperature Range	60 - 300°C / 140 - 572°F
Dimensions	48.2" x 21" x 16" / 1226 x 537 x 405mm
Packaging Dimensions	42.7" x 24" x 18" / 1085 x 615 x 465mm
Weight	63.9 lbs. / 29 kgs.
Packaging Weight	73 lbs. / 33 kgs.
Item Number	48387

TEMPERATURE SETTINGS AND TIMES

Setting	Temperature (Top and Bottom Heat)	Time (minutes:seconds)	
		Low Speed	High Speed
Dial 1	123.9°C / 255°F	8:55	6:00
Dial 2	176.7°C / 350°F	8:00	4:45
Dial 3	204.4°C / 400°F	7:45	4:15
Dial 4	215.6°C / 420°F	7:30	3:30
Dial 5	229.4°C / 445°F	7:15	2:00
Dial 6	254.4°C / 490°F	5:45	1:45
Dial 7	271.1°C / 520°F	5:30	1:30
Dial 8	285°C / 545°F	5:15	1:15
Dial 9	293.3°C / 560°F	5:15	1:10
Dial 10	310°C / 590°F	5:15	1:05

Installation

- Place on a level and stable surface.
- Keep the unit away from flammable objects.



Installation

- Ensure that the power cord and the socket are not damaged prior to use, and socket is the correct electrical rating for this toaster.

Operation

1. Turn the power to FULL power.
2. Set the conveyor speed on 4.
3. Allow warm-up time of 5 to 10 minutes.
4. Place a sample product on the conveyor belt to test the setting.
 - A. If toasting is too light, turn conveyor speed control clockwise to a slow speed.
 - B. If toasting is too dark, turn conveyor control clockwise to a faster speed.

RECOMMENDED BAKING TIMES

Product	Top Heat	Bottom Heat	Belt Speed
Pizza 12" Blanched	148.9°C / 300°F	204.4°C / 400°F	6 minutes
Meat and Cheese Sandwich	232.2°C / 450°F	148.9°C / 300°F	4 minutes
Meatball	260°C / 500°F	176.7°C / 350°F	2 minutes
Bagel (open)	260°C / 500°F	204.4°C / 400°F	2 minutes
1 oz. cookies	93.3°C / 200°F	121.1°C / 250°F	10 minutes
Garlic Bread Lightly Seasoned	260°C / 500°F	260°C / 500°F	2 minutes
Fish Sizzle Platter	204.4°C / 400°F	260°C / 500°F	6 minutes

Maintenance

CLEANING

DAILY

1. Turn main power switch to the OFF position, Disconnect unit from power source and allow unit to cool.
2. Using a mild detergent, wipe exterior surfaces, clean with a damp cloth.
 - A. For lightly soiled build-up, clean with a damp cloth.
 - B. For heavily soiled build-up, use a soft damp cloth and mild detergent. DO NOT USE CORROSIVE CLEANERS.
3. Remove the load and unload tray by lifting it out of position. Clean using mild detergent and warm water.
4. Remove each crumb tray by sliding each of them out from under the conveyor belt. Clean crumb tray by wiping with a damp cloth and mild detergent. DO NOT use corrosive cleaners. Place trays in place prior to

Maintenance

putting unit back into operating.

5. Reconnect power.

Note: When placing the tray back into position, be sure that the message “CAUTION HOT SURFACE” is the right side up.

WEEKLY

CLEANING THE CONVEYOR BELT

1. Turn power switch to the OFF position. Disconnection unit from power source and allow to cool.
2. Perform daily cleaning procedures.
3. Using a damp cloth, wipe the fan guard located on the box cover under the unit. Reconnect power or turn power back on.
4. Switch the ON/OFF switch to the ON position, and turn conveyor to its fastest setting (Make sure the heater is off).
5. With the conveyor turned on and the crumb tray in place, take a wire grill brush or dry abrasive pad, clean the exposed surface of conveyor belt by passing the brush or pad, back and forth across the surface of the conveyor belt as the belt moves past. Continue until the entire belt is clean. Make sure the crumb tray is installed, this will minimize the amount of particles that fall into the oven.
6. When the conveyor belt is clean, take a damp cloth and wipe the conveyor, removing any loose particles on the belt surface.
7. Remove the crumb tray by sliding it out from beneath the conveyor belt. Clean the crumb tray by wiping with a damp cloth and mild detergent.

- **Do not use corrosive cleaners.**
- **Do not run conveyor oven without crumb trays installed.**
- **Overheating to electrical components and premature failure can occur.**
- **Do not immerse or let the unit stand in water.**
- **Do not hose down the unit or the table/counter if the unit is on the table/counter.**
- **Keep away from running water.**

MONTHLY

REMOVAL AND CLEANING OF CONVEYOR BELT

1. Turn main power switch to the OFF position. Disconnect unit from its power source and allow to cool.
2. Perform daily and weekly cleaning procedures. To remove links, unhook each end of one link and bring the two ends together, and un-thread. Once detached, re-hook onto itself so not to get damaged.
3. Now that the links have been unhooked, the conveyor can now be carefully removed from the oven. Standing at one end of the oven. Starting with the end on the bottom, roll the conveyor belt until it has been totally removed. Take careful notice being sure not to damage the heater tubes, and working it over the drive sprockets.
4. Clean conveyor belt in deep sink, caustic cleaners may be used. For a heavy soiled conveyor belt, soak over night in hot soapy water.

Maintenance

NOTE: Do not attempt to clean the heater tubes.

5. Take this opportunity to clean and remove any loose materials inside the unit. Using a mild cleaner and damp cloth, carefully wipe the inside surfaces being sure NOT to clean the heater tubes. **DAMAGE CAN OCCUR TO THE HEATER TUBES FROM IMPROPER CLEANING. DO NOT SPRAY CLEANING SOLUTIONS INTO OVEN CAVITY.**
6. Reinstall conveyor belt by first laying the belt along the bottom of the oven cavity making sure the hooks on the sides are facing the inside and ends of the hooks will be pointing away from the direction of the belt so not to catch on any internal components once put back into operating. Also, being sure to properly align the belt over the conveyor drive sprockets.

NOTE: The direction of the belt.

7. Next, pull one end of the conveyor belt over the top of the sprockets, (being sure to line the links up properly with the sprockets) bring the two ends together.
8. Reinstall the previously removed master links as stated in step 2 & 3. Unhook the last link of the conveyor, farthest away from you, and re-thread through the other end, and reconnect back onto itself.
9. Examine the oven to assure proper installation, once satisfied, install crumb trays if you have not done so. **DO NOT OPERATE UNIT WITHOUT CRUMB TRAYS INSTALLED.**
10. Reconnect oven to power supply and check for proper operation.

LUBRICATE THE CHAIN & SPROCKETS EVERY MONTH

1. **DISCONNECT POWER SOURCE.**
2. Remove the panel which exposes chain drive.
3. Using an extreme pressure, synthetic chain lubricant with a temperature range up to 400°F. Apply liberally onto chain and sprockets.
4. Replace panel, reconnect power source and test unit.

Parts Breakdown

Model CE-CN-0356 48387

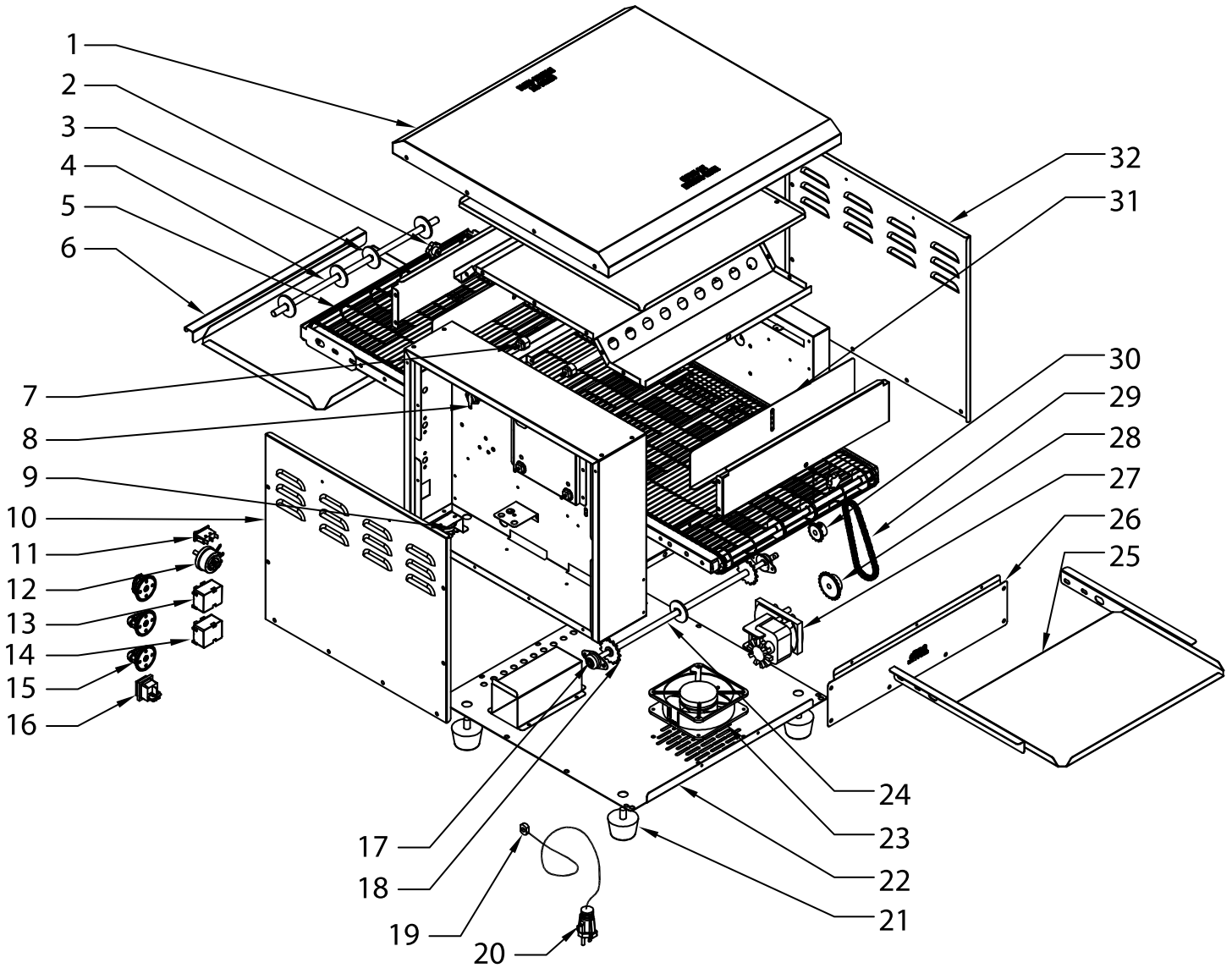

Parts Breakdown

Model CE-CN-0356 48387

Item No.	Description	Position	Item No.	Description	Position	Item No.	Description	Position
AL390	Lid for 48387	1	AL401	Speed Control for 48387	12	AL412	Fan for 48387	23
AL391	Handle for 48387	2	AL402	Top Thermostat for 48387	13	AL413	Active Shaft for 48387	24
AL392	Wheel for 48387	3	AL403	Bottom Thermostat for 48387	14	AL414	Tray for 48387	25
AL393	Driven Shaft for 48387	4	AL404	Knob for 48387	15	AL415	Back Plate for 48387	26
AL394	Conveyor for 48387	5	AL405	Switch for 48387	16	AL416	Motor for 48387	27
AL395	Tray for 48387	6	AL406	Bearing for 48387	17	AL417	Motor Sprocket for 48387	28
AL396	Element for 48387	7	AL407	Conveyor Belt Gear for 48387	18	AL418	Chain for 48387	29
AL397	Fan Switch for 48387	8	AL408	Bushing for 48387	19	AL419	Shaft Sprocket for 48387	30
AL398	Thermal Cut Out for 48387	9	AL409	Plug and Lead for 48387	20	AL420	Adjust the Baffle for 48387	31
AL399	Front Panel for 48387	10	AL410	Feet for 48387	21	AL421	Side Panel for 48387	32
AL400	Speed Switch for 48387	11	AL411	Bottom Plate for 48387	22			

Electrical Schematics

Model CE-CN-0356 48387

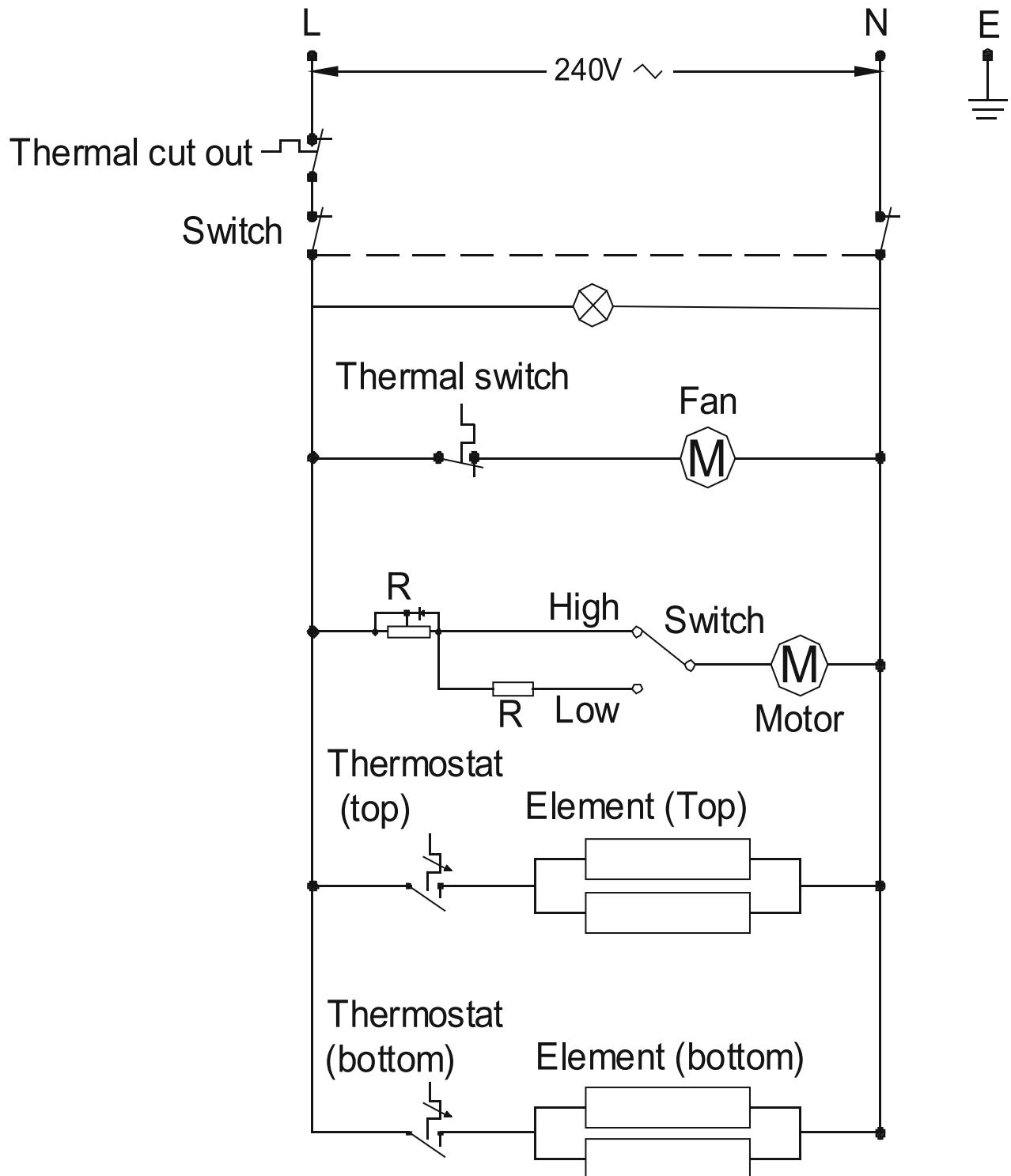



Warranty Registration

Thank you for purchasing an Omcan product. To register your warranty for this product, complete the information below, tear off the card at the perforation and then send to the address specified below. You can also register online by visiting:

Merci d'avoir acheté un produit Omcan. Pour enregistrer votre garantie pour ce produit, complétez les informations ci-dessous, détachez la carte au niveau de la perforation, puis l'envoyer à l'adresse spécifiée ci-dessous. Vous pouvez également vous inscrire en ligne en visitant:

Gracias por comprar un producto Omcan usted. Para registrar su garantía para este producto, complete la información a continuación, cortar la tarjeta en la perforación y luego enviarlo a la dirección indicada a continuación. También puede registrarse en línea en:

<https://omcan.com/warranty-registration/>

For mailing in Canada

Pour postale au Canada

Por correo en Canadá

OMCAN

PRODUCT WARRANTY REGISTRATION

3115 Pepper Mill Court,

Mississauga, Ontario

Canada, L5L 4X5

For mailing in the US

Pour diffusion aux États-Unis

Por correo en los EE.UU.

OMCAN

PRODUCT WARRANTY REGISTRATION

4450 Witmer Industrial Estates, Unit 4,

Niagara Falls, New York

USA, 14305

or email to: service@omcan.com



Purchaser's Information

Name: _____

Address: _____

City: _____ Province or State: _____ Postal or Zip: _____

Country: _____

Dealer from which Purchased: _____

Dealer City: _____ Dealer Province or State: _____

Invoice: _____

Model Name: _____ Model Number: _____

Machine Description: _____

Date of Purchase (MM/DD/YYYY): _____

Would you like to extend the warranty? Yes No

Company Name: _____

Telephone: _____

Email Address: _____

Type of Company:

Restaurant Bakery Deli

Butcher Supermarket Caterer

Institution (*specify*): _____

Other (*specify*): _____

Serial Number: _____

Date of Installation (MM/DD/YYYY): _____

Thank you for choosing Omcan | Merci d'avoir choisi Omcan | Gracias por elegir Omcan



Since 1951 Omcan has grown to become a leading distributor of equipment and supplies to the North American food service industry. Our success over these many years can be attributed to our commitment to strengthen and develop new and existing relationships with our valued customers and manufacturers. Today with partners in North America, Europe, Asia and South America, we continually work to improve and grow the company. We strive to offer customers exceptional value through our qualified local sales and service representatives who provide convenient access to over 6,500 globally sourced products.

Depuis 1951 Omcan a grandi pour devenir un des “leaders” de la distribution des équipements et matériel pour l’industrie des services alimentaires en Amérique du Nord. Notre succès au cours de ces nombreuses années peut être attribué à notre engagement à renforcer et à développer de nouvelles et existantes relations avec nos clients et les fabricants de valeur. Aujourd’hui avec des partenaires en Amérique du Nord, Europe, Asie et Amérique du Sud, nous travaillons continuellement à améliorer et développer l’entreprise. Nous nous efforçons d’offrir à nos clients une valeur exceptionnelle grâce à nos ventes locales qualifiées et des représentants de service qui offrent un accès facile à plus de 6500 produits provenant du monde entier.

Desde 1951 Omcan ha crecido hasta convertirse en un líder en la distribución de equipos y suministros de alimentos en América del Norte industria de servicios. Nuestro éxito en estos años se puede atribuir a nuestro compromiso de fortalecer y desarrollar nuevas relaciones existentes con nuestros valiosos clientes y fabricantes. Hoy con socios de América del Norte, Europa, Asia y América del Sur, que trabajan continuamente para mejorar y crecer la empresa. Nos esforzamos por ofrecer a nuestros clientes valor excepcional a través de nuestro local de ventas y representantes de los servicios que proporcionan un fácil acceso a más de 6,500 productos con origen a nivel mundial.

